



DESCRIPTION

TB20 – TB20/2

Adjustable thermal balancing valve for sanitary hot water recirculation systems, made by lead free corrosion resistant brass conform to European (UBA-List & 4 MS) and USA (NSF) standard requirements. Available with female x female and male x male connections. Available options: T39P/80 thermometer and reduction OTB02 ½ "M x (M10x1) to install a probe for remote monitoring of the water temperature.

Dimensions

TB20 – Female x Female

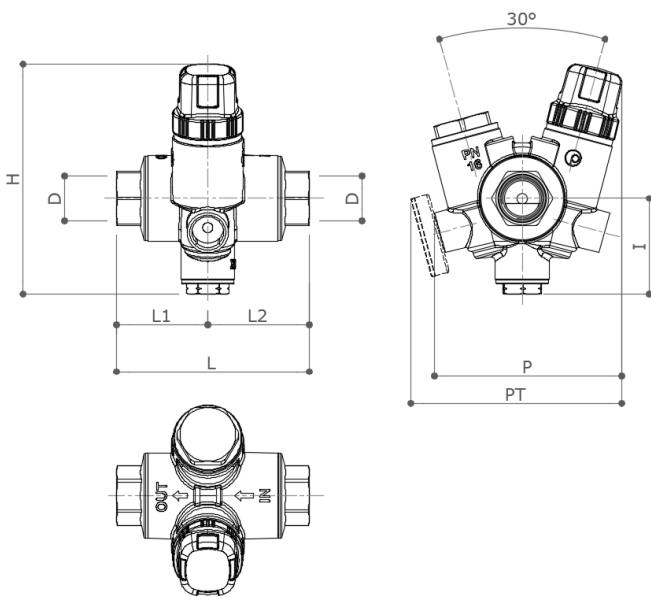

TB20/2 – Male x Male

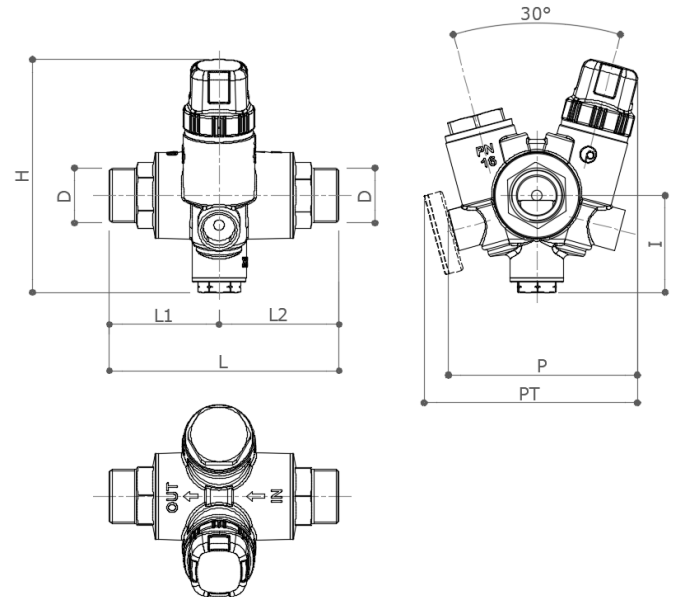

	D	L	L1	L2	H	I	P	PT	Weight (gr)
F x F	½" EN10226-1	93	44	49	113	48	91	102	925
F x F	¾" EN10226-1	99	47	52	113	48	91	102	930
M x M	¾" M ISO228	110	52.5	57.5	113	48	91	102	925

Dimension mm - PT = with Optional thermometer (T39P/80 Optional) – drywell ½" M

MATERIALS

Body	CW511L (EN 12165)-CuZn38As-ASTM C27453	Protection Handwheel	PA66
Fitting	CW511L (EN 12165)-CuZn38As-ASTM C27453	Presetting Handwheel	ABS
Cap	CW511L (EN 12165)-CuZn38As-ASTM C27453	Spring	AISI302
O-ring	EPDM-X	Shutter	PSU

CHARACTERISTICS

Max working pressure	16 bar	Accuracy	±2°C
Maximum Differential Pressure	1 bar	Default Presetting	52°C
Max working temperature	90°C	K_{vmax}	1,8
Temperature setting range	35° - 60°C	K_{vmin} (T>60°C)	0,2

OPERATING PRINCIPLE

Thermostatic balancing valve TB20 - TB20/2 solve the balancing/temperature setting problems typical of sanitary hot water recirculation systems.

It often happens that the furthest users from the generator are penalized and consequently are supplied with domestic hot water that does not reach the minimum desired temperature value. These situations are perceived by users as a malfunction of the system itself.

The presence of a thermosensitive element (which is the heart of the valve itself) allows you to automatically balance the flow in the recirculation network depending on whether the water temperature exceeds the pre-set value or not. Having established in advance an equal delivery temperature value for all the thermostatic balancing valves installed (for example 52 ° C), all the distribution risers will be supplied by hot domestic hot water at the desired temperature.

Thanks to the presence of a presetting device (selectable by removing the protective knob) the user has the possibility to set the desired temperature value ranging in the range 35 ° - 60 ° C (factory presetting 52°C). It is good practice that all the valves of the same system are set to the same value.

The following diagram shows the variation of the flow rate (expressed as Kv) as a function of the temperature of the water flowing across the thermostatic balancing valve. Practically three distinct areas of operation can be identified.

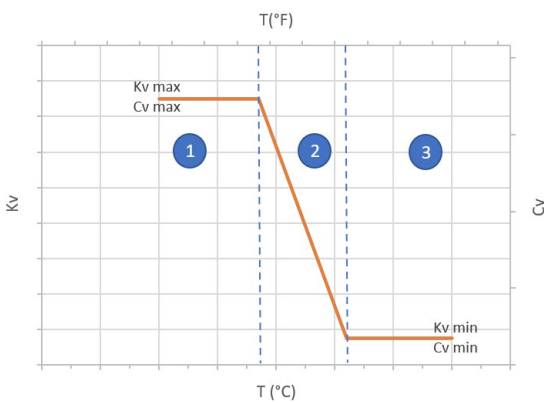

- Working area 1 – Maximum K_{vmax} , $T_{water} \ll T_{presetting}$**
In this temperature range the valve is completely open and a spring is balancing the thermostatic element variations
- Working area 2 - variable K_v , when T_{water} is reaching $T_{presetting}$.**
When the water temperature is reaching the selected temperature, the thermostatic element is expanding and is closing the valve till the minimum design K_{vmin}
- Working area 3 - K_{vmin} , $T_{water} \geq T_{presetting}$**
When the water temperature is more than the selected temperature the thermostatic element is keeping the valve in closed position and only the minimum flow rate is guarantee, K_{vmin}

The TB20 is not a shut off valve, a minimum flow rate K_{vmin} is guarantee.
TB20 is not design with features to guarantee antilegionella operations, if you need it please refer to the model TB30 or TB50

THERMOWELL FOR TEMPERATURE SENSOR

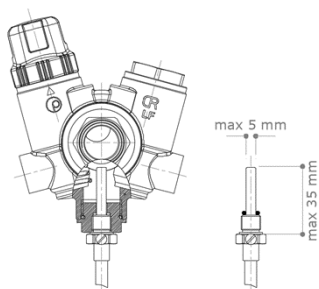

TB20 and TB20/2 has a drywell (1/2") that could be used (through an optional reduction OTB02 ½ "M x (M10x1)), to install a probe for remote monitoring of the water temperature.

Suggested size of the probe should be followed to select the right dimension thermowell diameter/length and sensors.

The thermowell and the sensor allow the remote control and monitoring of the temperature of the water during normal operation and disinfection operations.

PRESETTING OPEARTION.

TB20 valves has factory presetting at 52°C (corresponding to position ▼ on the selector), the user can change the presetting by following the instructions:

1. Remove the handwheel protection cap
2. Turn the selector to the target position

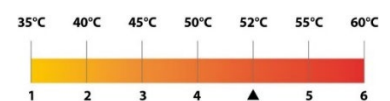

This is a simple but important operation for the proper functioning of the system. It is always advisable to preset the system valves at a temperature value greater than 3-5 ° C compared to the temperature actually desired on the most penalized users. This way, the overall pressure losses will be limited to the advantage of choosing the circulator dedicated to the recirculation network.

EXAMPLE OF CALCULATION/DESIGN

The correct sizing of the system and the evaluation of the impact that each component can have in the fluid dynamics of the same is always the root of good operation. It is therefore essential to evaluate the incidence of the thermostatic balancing valve in the overall calculation of the pressure drops for the choice of the type of needed circulator. An explanatory practical example is given below.

Consider a 3-storey residential complex characterized by the presence of 5 risers for the distribution of sanitary water, each of it consists of the Hot Water (ACS) riser, the Cold Water riser (AFS) and the Recirculation R.

To guarantee to the most penalized thermostatic balancing valve a flow of water whose temperature (T_{SF}) is not lower than 5 °C with respect to the outlet of the generator (T_G), each flow rate can be calculated considering the heat losses along the entire line from the generator to the last thermal balancing valve.

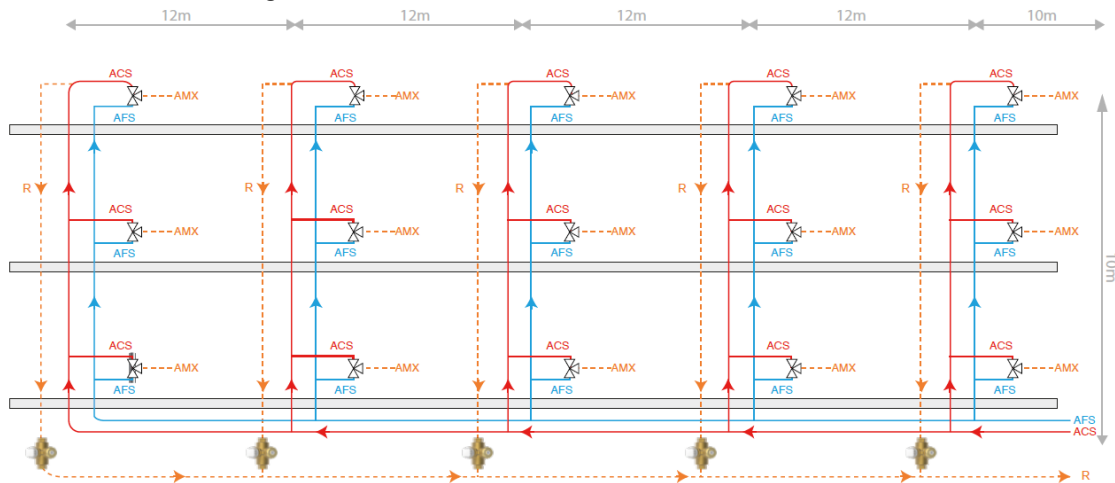

Hypothesis:

1. ACS temperature $T_G = 57^\circ\text{C}$
2. Valve selected temperature TB 52°C (pos. ▼ - default)
3. Heat losses of the pipes. $q_l = 10 \text{ W/m}$
4. Maximum temperature drops through the system, risers and horizontal manifold. $\Delta T = T_G - T_{SF} \leq 5\text{K}$

For each riser and for each stretch of horizontal manifold, the extent of the heat losses are evaluated and, based on that, the amount of water flowrate to ensure a $\Delta T = 5\text{K}$ is determined.

Circuit n°	Total vertical length (ACS + R) (m)	Vertical riser Heat losses (W)	Total horizontal manifold length (m)	Horizontal manifold heat losses (W)	Total heat loss for every complete circuit (W)	Total heat loss (W)	Riser flow rate (l/h)	Total flow rate (l/h)
1	20	200	10	100	300	1580	37	272
2	20	200	12	120	320	1280	41	235
3	20	200	12	120	320	960	46	195
4	20	200	12	120	320	640	57	148
5	20	200	12	120	320	320	91	91

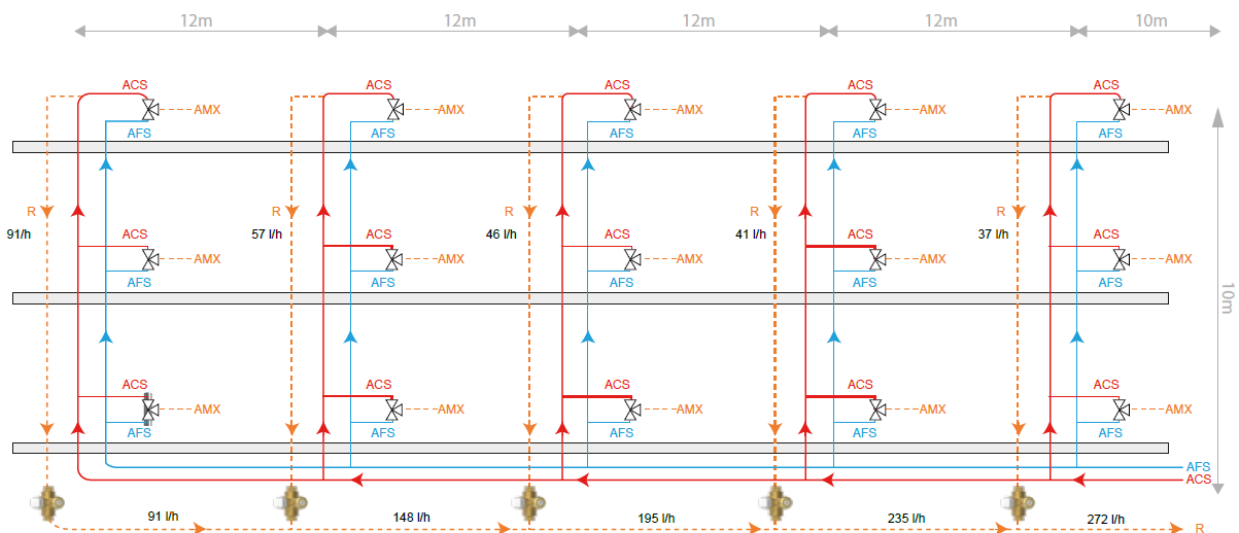

Based on the flow rate value calculated for the most penalized riser by heat losses (Column n ° 5 - 91 l / h), the available water temperature (TG = 57 ° C) and the maximum temperature jump (5K) allowed as an initial hypothesis and the preset value, the Kv and the relative pressure drop at 52 ° C will be evaluated (with an excellent approximation corresponding to the position ▼ on the valve). Through the characteristic diagram of the TB20 thermostatic balancing valve (or from the relative table values shown below for ease of reference) the Kv value settles at 0.45

°T	1	2	3	4	▼	5	6
°C	Kv	Kv	Kv	Kv	Kv	Kv	Kv
20,0	1,82	1,82	1,82	1,82	1,82	1,82	1,82
22,5	1,82	1,82	1,82	1,82	1,82	1,82	1,82
25,0	1,78	1,82	1,82	1,82	1,82	1,82	1,82
27,5	1,45	1,82	1,82	1,82	1,82	1,82	1,82
30,0	1	1,78	1,82	1,82	1,82	1,82	1,82
32,5	0,65	1,5	1,82	1,82	1,82	1,82	1,82
35,0	0,45	1,12	1,82	1,82	1,82	1,82	1,82
37,5	0,3	0,7	1,7	1,82	1,82	1,82	1,82
40,0	0,28	0,45	1,3	1,82	1,82	1,82	1,82
42,5	0,27	0,31	0,9	1,78	1,82	1,82	1,82
45,0	0,25	0,25	0,5	1,45	1,75	1,82	1,82
47,5	0,24	0,24	0,35	0,85	1,4	1,79	1,82
50,0	0,23	0,23	0,28	0,48	0,8	1,5	1,82
52,5	0,22	0,22	0,22	0,35	0,45	0,85	1,72
55,0	0,21	0,21	0,21	0,28	0,32	0,45	1,35
57,5	0,205	0,205	0,205	0,26	0,25	0,33	0,7
60,0	0,2	0,2	0,2	0,24	0,2	0,28	0,45
62,5	0,2	0,2	0,2	0,22	0,2	0,22	0,32
65,0	0,2	0,2	0,2	0,21	0,2	0,2	0,24

$$\Delta P = \left(\frac{Q}{100 \times Kv} \right)^2 = \left(\frac{91}{100 \times 0,45} \right)^2 = 4.1 \text{ kPa}$$

At this pressure drop we must add:

1. Headers and risers' pressure drops.
2. Recirculation circuit pressure drops.

The total pressure drop together with the flow value has to be used to select the right pump.

Kv vs. TEMPERATURES CHART

Below is the characteristic operating diagram of the TB20 and TB20/2 valves which shows the Kv value as a function of the temperature of the water passing through the valve and the presetting value selected.

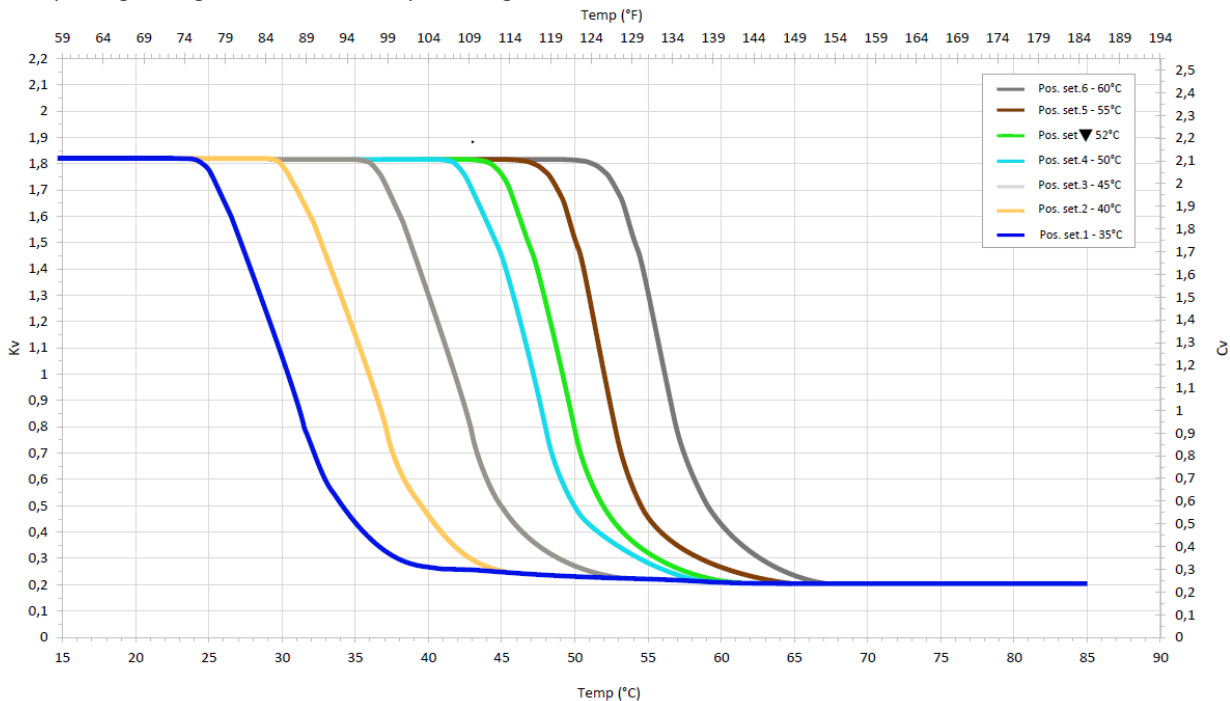

INSTALLATION.

The TB20 Valve can be installed both at the top or at the bottom of the riser, with the following considerations:

- Accessible
- At least 0.5 meters from the headers
- With the right orientation considering flow rate direction

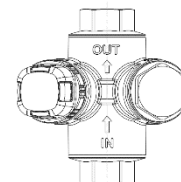

The TB20-TB20 / 2 series thermostatic balancing valve can be installed without any particular precautions regarding the position; it can be installed both vertically and horizontally and possibly also upside-down. Not being equipped with built-in filters or electrical/electronic elements, there is no risk.

As for all types of balancing valves (whether they are intended for air conditioning systems or as in this case for sanitary distribution systems), in order to avoid operating problems, it is always recommended to install means of suitable filtering capacity in the systems, such as the 51F - FILTERBALL ball valves with incorporated strainer.

ACCESSORIES

T39P/80

Double scale 0-80°C / 32°-176°F



OTB02

Adaptor/reduction OTB02 1/2" M x (M10x1) for probe to monitoring the water temperature.



TB100CK

Union Ball valve DN20 with integrated check valve to be used downstream the TB20/2.

Sizes available:

1/2" F x 3/4" F swivel nut

3/4" F x 3/4" F swivel nut



TB100

Union Ball valve DN20 to be used upstream the TB20/2.

Sizes available:

1/2" F x 3/4" F swivel nut

3/4" F x 3/4" F swivel nut

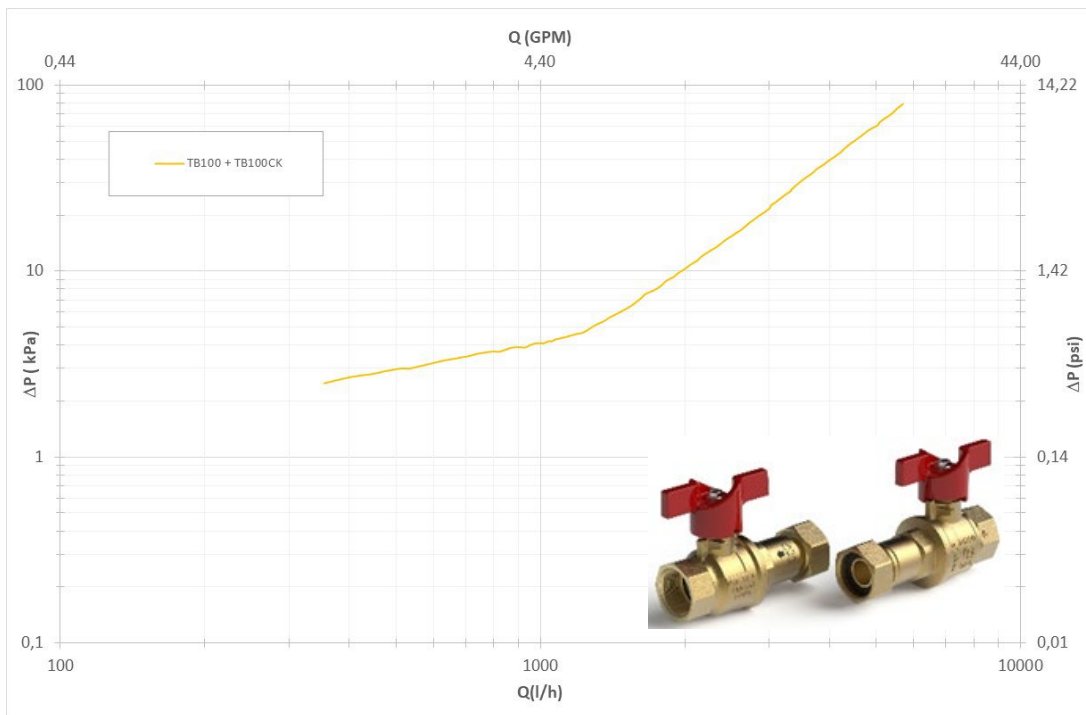

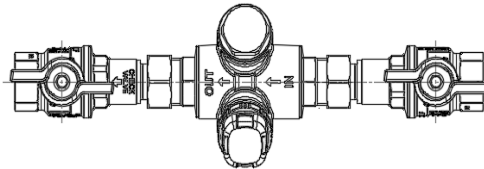
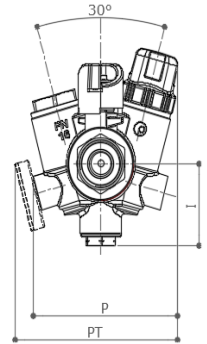
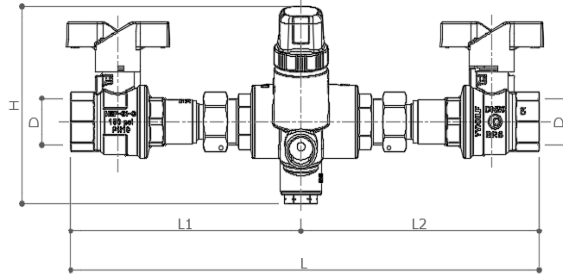

	D	L	L1	L2	H	I	P	PT
Fx F	½" EN10226-1	293	144	149	112	46	91	102
Fx F	¾" EN10226-1	293	144	149	112	46	91	102

OTB00CK

Check valve MxF to be used downstream the TB20.

Body: CW511L

Check Valve: Noryl GF

Sizes Available:

½ F x ½" M

¾ F x ¾" M

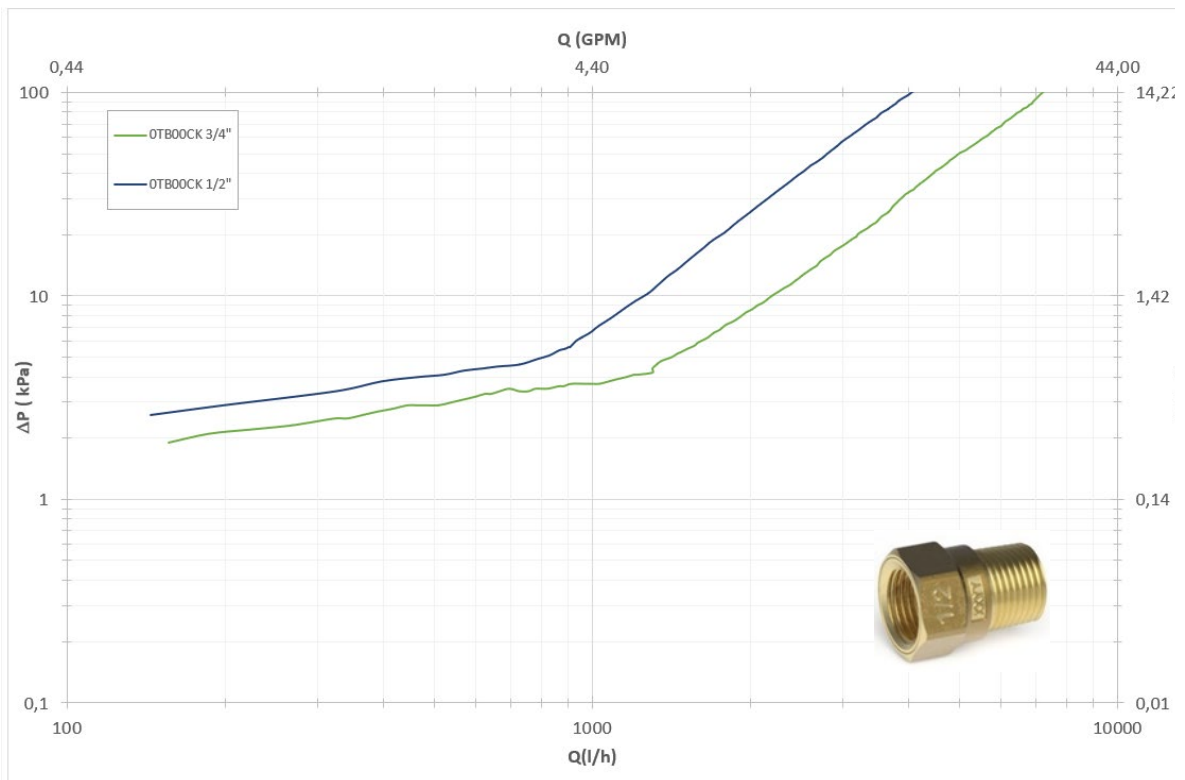

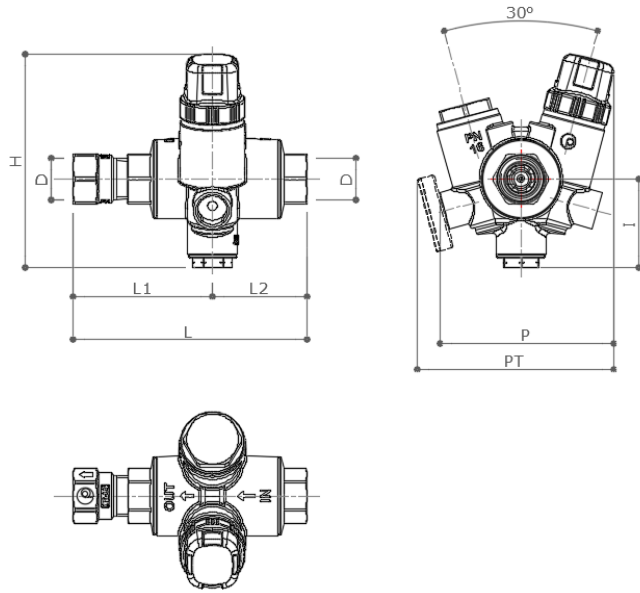

	D	L	L1	L2	H	I	P	PT
F x F	1/2" EN10226-1	122	73	49	112	46	91	102
F x F	3/4" EN10226-1	138	86	52	112	46	91	102