



DESCRIPTION

502

F x F union end pressure reducer with pressure compensation system. For hot water (max 95°C). Yellow finish.

Thanks to compensation chamber and the membrane free design (no wear and tear on it), the system is stable to pressure damping and water hammer.

It is suggested to install a strainer (168/O – 170 or 51F Filterball®) upstream in order to avoid any damage to internal components of the reducer caused by impurities.

The pressure reducer G $\frac{1}{4}$ ” pressure gauge on both sides which can fit a monometer **M500P** (not included) in order to measure the pressure downstream.

DIMENSIONS

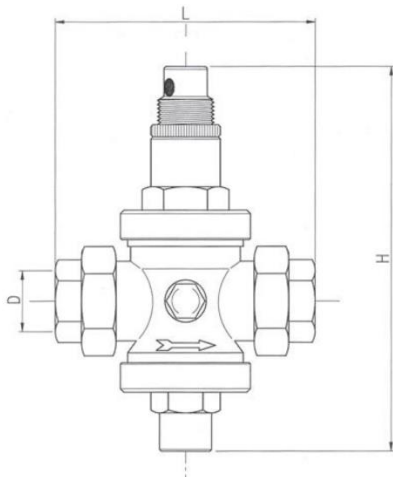

D	½”	¾”	1”	1 ¼”	1 ½”	2”
H	120	160	166	220	220	250
I	12	15	16	18	18	22
L	112	135	140	170	175	200
Weight [g]	930	1600	1850	2950	3400	5300

Dimensions in mm

All threads are conform to ISO 228 standard

MATERIALS

- Body** CW617N (EN 12165) CuZn40Pb2
- Spring (1)** Steel, cadmium plated
- Diaphragm (2)** CW614N (EN 12164) CuZn39Pb3
- Seat (3)** Stainless steel AISI 303
- Stem with shutter (4)** CW614N (EN 12164) CuZn39Pb3
Stainless steel AISI 303 (1 ¼” – 2”)
- Spring Holder** CW614N (EN 12164) CuZn39Pb3
- Compensation chamber (5)**
- Nut** CW617N (EN 12165) CuZn40Pb2
- Union** CW617N (EN 12165) CuZn40Pb2
- O-Ring** FKM
- Gasket** Fiber

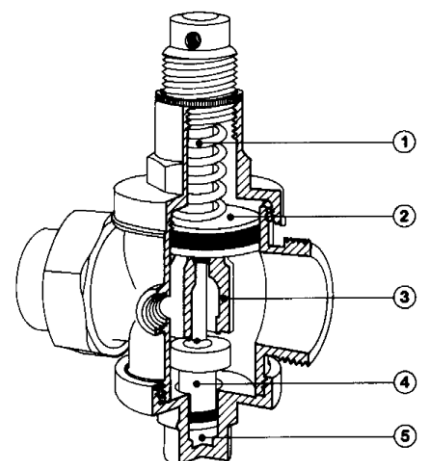

PRESSURE DROP DIAGRAM

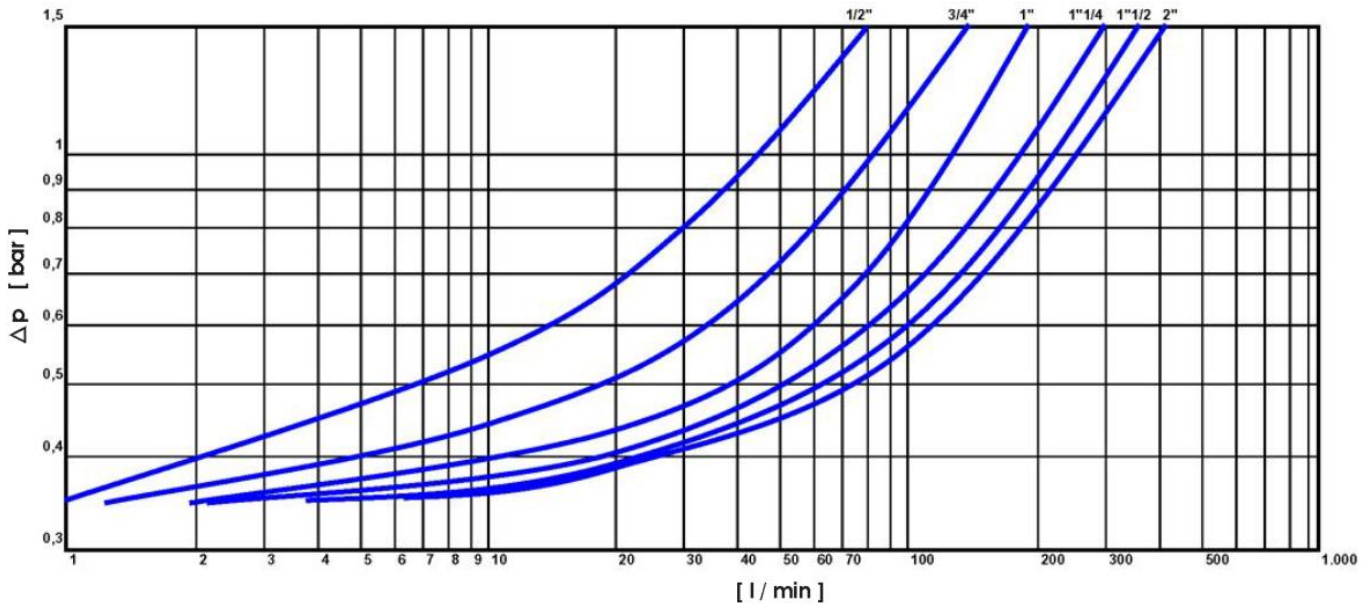

D	1/2"	3/4"	1"	1 1/4"	1 1/2"	2"
Suggested flow rate [m3/h]	1.2 – 3	3 – 4.5	4.5 – 6	6 – 8	7 – 8.5	7.5 - 10
Suggested flow rate [l/min]	20 – 50	50 – 75	75 – 100	100 – 130	117 – 142	125 - 167

Max upstream pressure: 25 bar

Downstream pressure: 0.5 bar to 6 bar

RECOMMENDED WORKING TEMPERATURE/PRESSURE LIMITS

Max suggested operative upstream pressure: 20 bar

Max suggested operative downstream pressure: 6 bar

Pressure reduction ratio: 10 : 1

Max working temperature: 95°C

INSTALLATION AND COMMISSIONING

The pressure reducer 502 can be installed in every orientation (horizontal, vertical, upside down, oblique).

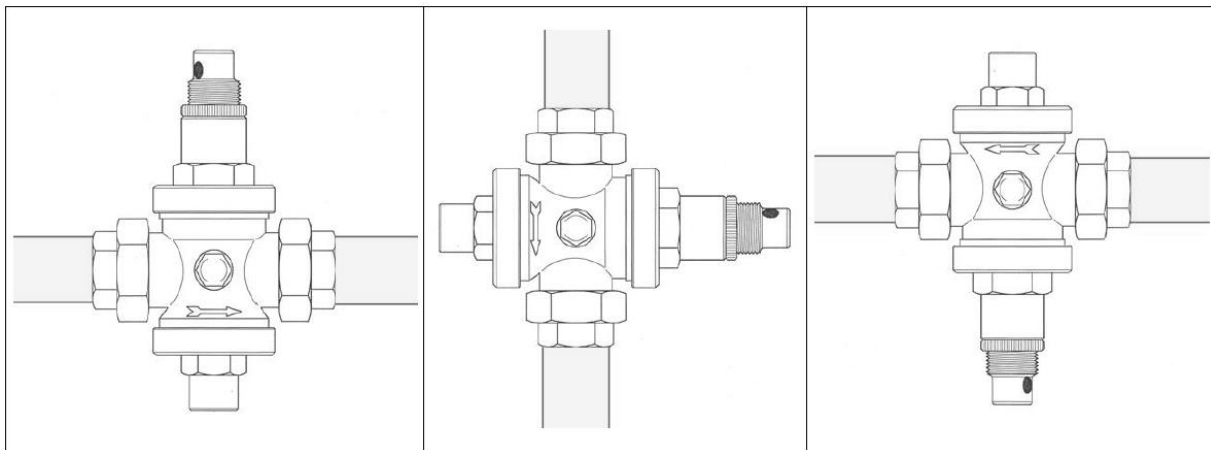

Please check that the flow direction is concurrent to the arrow on the reducer body. Commissioning and pressure set-up is done by rotating the brass spring holder on the top; to do it (see pictures below), loosen the plastic lock ring, turn the spring holder using a screwdriver (clockwise to increase outlet pressure, counter clockwise to decrease outlet pressure), tighten the plastic ring.



In order to set the system correctly, it has to be closed and a manometer **M500P** (not included) has to be installed.

To avoid over-pressure (opening of the safety valve), water hammer and water return due to volume increase of hot water (it can occur when an electric boiler, a mixer or hot water tank is installed downstream the reducer) please install a check valve and a little expansion vessel between the heat source and the pressure reducer.

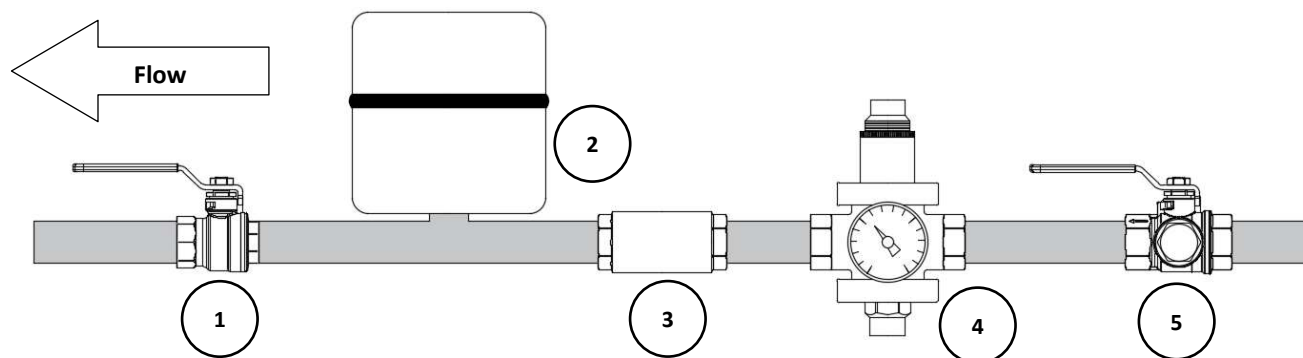

1 – Isolating ballvalve (51CE)
2 – Expansion vessel
3 – Check valve (188)
4 - Pressure reducer (500)
5 – Strainer and isolating valve (51F)